

Thermoheat by



HDF/HDC

## Ex Mineral insulated (MI) Cupro-Nickel heating cables

Mineral Insulated (MI) Cupro-Nickel heating cable is suitable to operate to a maximum sheath temperature of 400°C. MI Cupro-Nickel cables are widely used within a range of industrial applications, from oil and gas, chemicals and petrochem, power generation,

gas storage and many other industrial applications. The Cupro-Nickel copper conductor range (HDC) has been developed to combat severe on-site corrosive conditions. This range has low electrical resistance values required for long pipeline applications.

MI cable features:

- Corrosion resistance
- High performance output
- High resistance to mechanical abuse
- Safety and fire resistance

### Heating cable construction

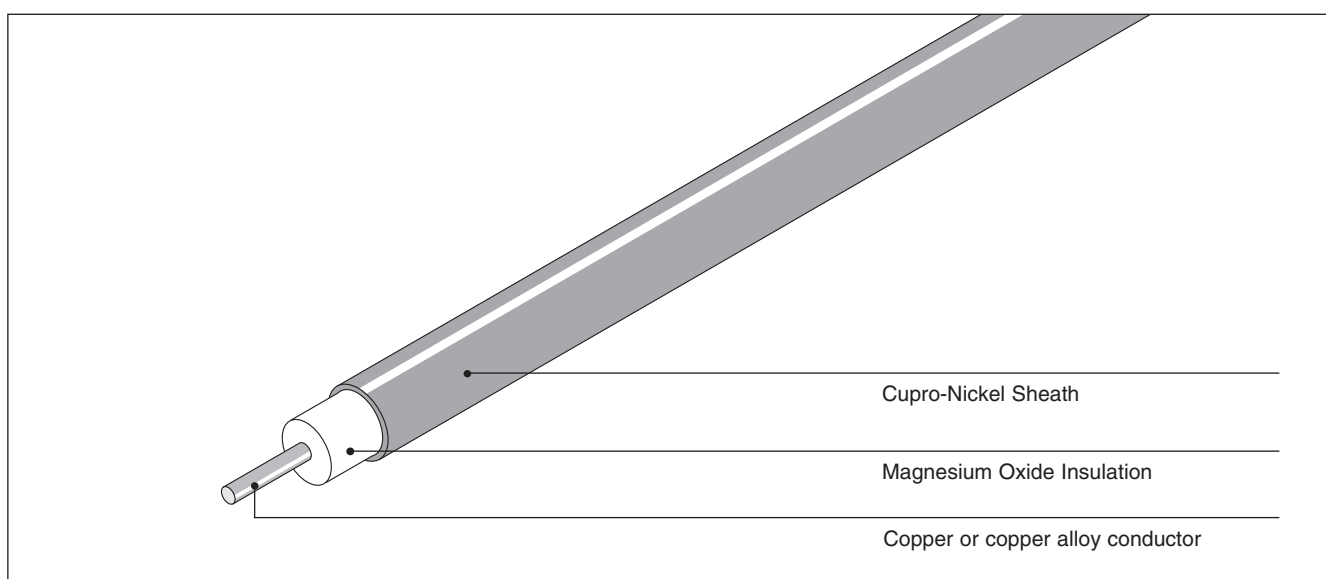

### Cupro-Nickel Heating Cable

Cable Sheath Material	70/30 Cupro-Nickel
Cable Insulation Material	MgO (Magnesium Oxide)
Cable Conductor Material	Copper or copper nickel alloy
Supply Voltage	Up to 300/500 VAC
Withstand Voltage	2.0 kV rms ac
Insulation Resistance	1000 MΩ/1000 m (Factory pass level)
Maximum Allowable Sheath Temperature	400°C
Earth Leakage	3mA/100 m (Nominal at 20°C)
Approvals	Baseefa 2001 Ltd. Ex II 2 G EExe II T6 to T1 Actual T class temperature determined by design *T1 (400°C) BAS02ATEX0046X (Units) BAS02ATEX0045U (Bulk cable) GOSGORTECHNADZOR KAZAKH GOST
Area Classification	Hazardous area, Zone 1 and Zone 2, Ordinary
Minimum installation temperature	-60°C
Minimum bending radius	6 x OD. (Outside diameter cable) at -60°C
Minimum cable spacing	25 mm
Resistance correction factor	Temperature coefficient of resistance for copper conductor - $\alpha = 0.00393$ per °C



**Technical Data**

Cable Ref:	Cable Diameter (mm)	Conductor Material	Conductor Diameter (mm)	Resistance (Ω/km)	Nominal Coil Length (m)	Coil Diameter (mm)	Approx Weight (kg/km)
HDF1M1600	3.2	Copper Alloy	0.62	1600	625	850	40
HDF1M1000	3.4	Copper Alloy	0.79	1000	550	850	45
HDF1M630	3.7	Copper Alloy	1.00	630	465	850	55
HDF1M400	4.0	Copper Alloy	1.25	400	400	850	67
HDF1M250	4.4	Copper Alloy	1.58	250	330	850	84
HDF1M160	4.9	Copper Alloy	1.97	160	265	850	108
HDC1M63	3.2	Copper	0.59	63	620	850	39
HDC1M40	3.4	Copper	0.74	40	550	850	44
HDC1M25	3.7	Copper	0.94	25	440	850	55
HDC1M17	4.6	Copper	1.14	17	300	850	84
HDC1M11	4.9	Copper	1.41	11	265	850	98
HDC1M7	5.3	Copper	1.77	7	225	850	119
HDC1M4	5.9	Copper	2.34	4	180	850	155

**Note:** All resistances shown are nominal at 20°C.

Tyco Thermal Controls requires the use of a 30 mA residual current device to provide maximum safety and protection from fire. Where there is a marked increase in nuisance tripping, a maximum 300 mA residual current device may be used.

\*Also refer to the components section (page 77) for more details on heating units, accessories and nomenclatures.

**Maximum operating temperatures**

Follow steps below to obtain sheath temperature guidelines from the graph, for ordinary area applications.

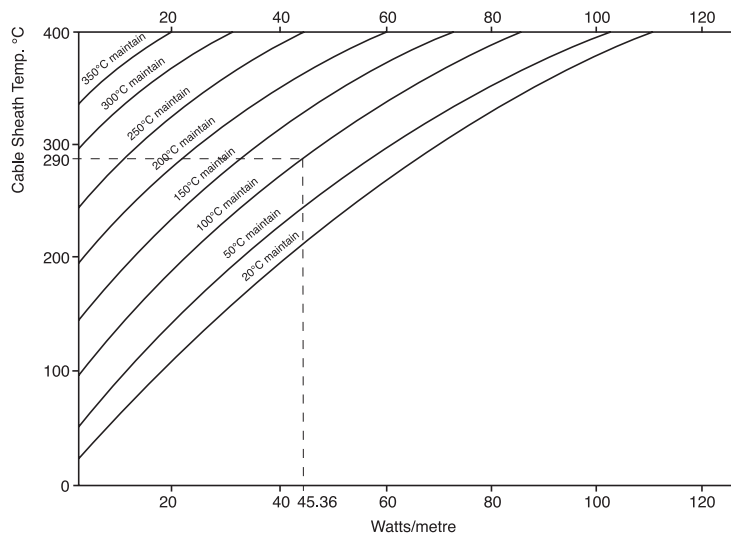

**Rating factor table**

Cable Ref.	Rating factor
HDF1M1600	1.000
HDF1M1000	.948
HDF1M630	.880
HDF1M400	.822
HDF1M250	.756
HDF1M160	.688
HDC1M63	1.000
HDC1M40	.948
HDC1M25	.880
HDC1M17	.727
HDC1M11	.688
HDC1M7	.644
HDC1M4	.590

- Step 1:** By design, identify cable reference to be used and calculate watts/metre rating of cable/element e.g. HDF1M250, 60W/m.
- Step 2:** Refer to rating factor table and multiply watts/metre rating of cable/element by rating factor to obtain adjusted watts/metre value. (60 W/m x 0.756 = 45.36 W/m)
- Step 3:** Using adjusted value, enter graph on watts/metre axis and obtain cable sheath temperature for application maintain temperature. Cable sheath temperature = 290°C for 100°C maintain - see graph.

**MI Heating cable sheath corrosion resistance and temperature data**

Sheath Material	Maximum Cable Sheath Temp (°C)	Description	Sulphuric Acid	Hydrochloric Acid	Hydrofluoric Acid	Phosphoric Acid	Nitric Acid	Organic Acid	Alkalis	Sea Water	Chloride
Cupro-Nickel	400	Cupro-Nickel sheathed cable 70% copper 30% nickel	NR	X	X	X	X	X	X	GE	GE

**Note:** NR Not recommended, A acceptable, GE Good to excellent, X Check for specific data

\* Corrosion resistance data is dependent on temperature and concentration.